

## CFM 850 Coating System

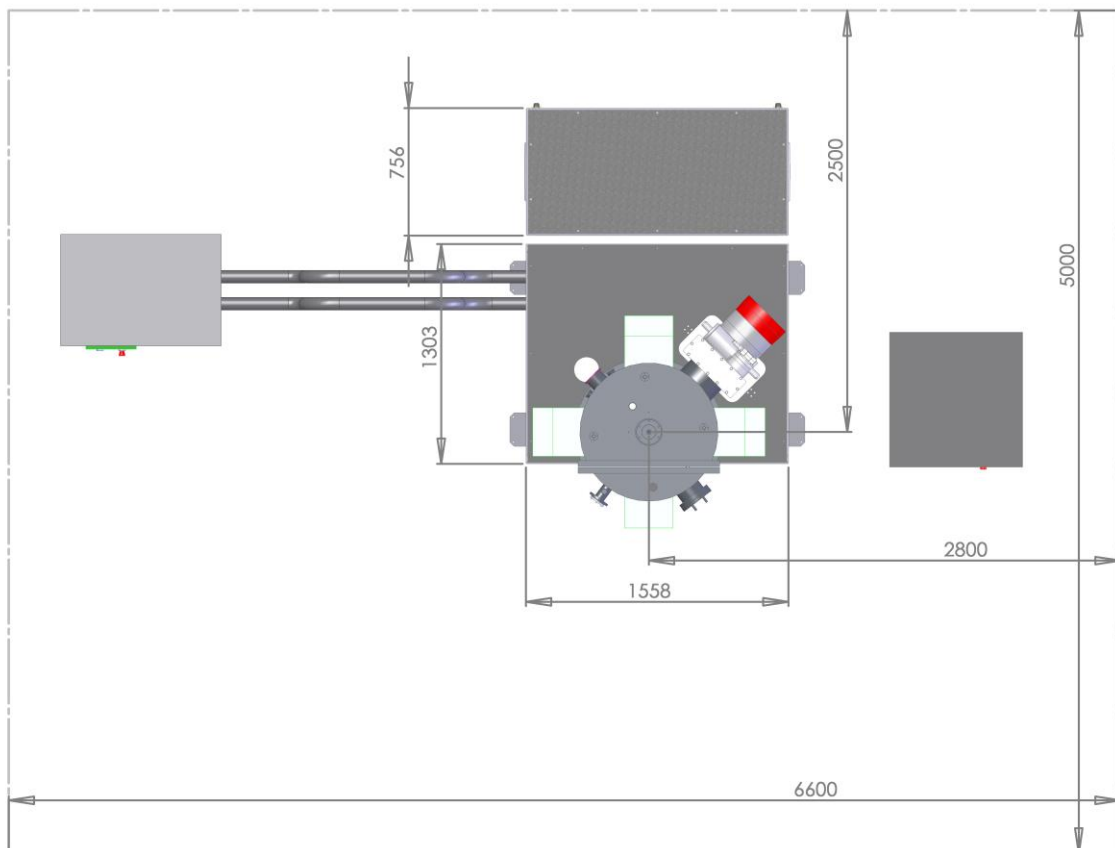
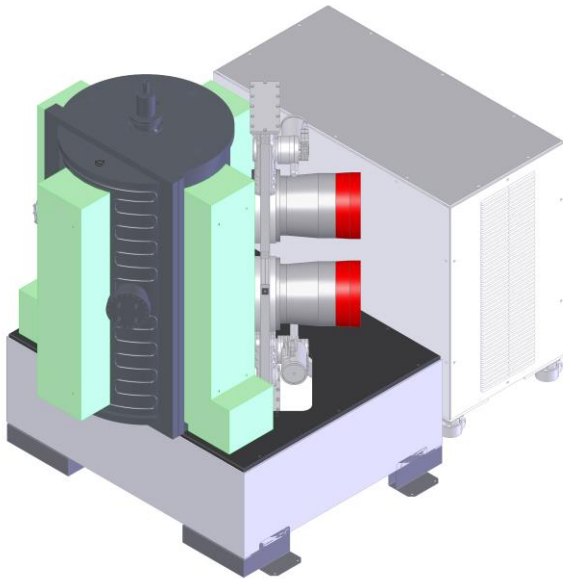

The floor area shown is the minimum and a larger area may be required, depending on access, doorways and so on. The control rack is moveable, limited by the length of connecting cables, but the Meissner chiller is connected to the vacuum system by rigid hoses and cannot be moved once installed. Roughing pumps are in a separate wheeled unit connected to the vacuum system via semi-flexible stainless steel hoses. A water chiller is also required: this should preferably be installed on the same floor level, to avoid pressure problems, and this will need appropriate ventilation and noise shielding; contact the factory for details of

suitable chillers. Access and storage space is also required for trolleys to handle the coating drum(s) and to exchange the magnetron targets.